

# Product Guide

## User and Maintenance Information

**IMPORTANT INFORMATION:**  
Please save this product guide.

## C150 Childsize Wheelbarrow

### Recommended Use

The wheelbarrow is simple, graceful, and strong. Ideal for work or play. The two big wheels give stability and balance, and will carry a playmate as easily as a pile of stones.

#### **⚠ WARNING**

- ▲ This product is intended for use by children of immature judgement therefore supervision is required at all times.

#### **⚠ CAUTION**

- ▲ Store indoors. This wheelbarrow is not water-proof.

### Assembly

Your wheelbarrow comes in one carton containing:

1. One wheelbarrow.
2. This product guide.

**If your shipment is incomplete, please contact Customer Service.**

### Maintenance

Periodically inspect for cracks, breaks, loose parts, missing parts, and/or malfunctions. Remove the product from service when any condition develops that might make operation unsafe.

### Cleaning

Wipe the wood parts with a damp cloth and a mild detergent. Do not use excessive water.

### Construction

The wooden components are manufactured from durable birch plywood or solid maple with a clear nontoxic finish. The 8" wheels feature durable rubber tires.

### User Modifications

We are not responsible for modifications made by customers to our products in the field, without our supervision, testing or evaluation.

### Ordering Parts

To order replacement parts, contact Customer Service with a description of the part(s) needed and the ID Code from the product.

**Use only replacement parts supplied by Community Playthings.**

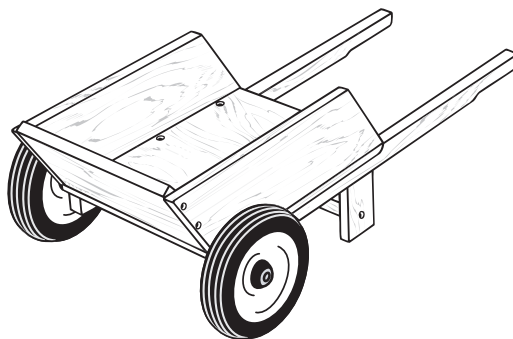

### CUSTOMER SERVICE:

#### United States

PO Box 2

Ulster Park, NY 12487

Office hours: 9-5 EST

Phone (800) 777-4244

Fax (800) 336-5948

(845) 572-3468

[www.CommunityPlaythings.com](http://www.CommunityPlaythings.com)

[Sales@CommunityPlaythings.com](mailto:Sales@CommunityPlaythings.com)

